

# 6kW Time Lag Control Box

Safety Instructions and Operation Manual  
900196S



**Heat Outdoors**  
Unit 9, Stort Valley Industrial Estate  
Stansted Road, Bishop's Stortford  
Hertfordshire, United Kingdom  
CM23 2TU

[www.heat-outdoors.co.uk](http://www.heat-outdoors.co.uk)  
01279 466500  
[info@heat-outdoors.co.uk](mailto:info@heat-outdoors.co.uk)

# Important Safety Instructions

- Make sure the instructions are stored in the safe place for future reference.
- Check if the voltage indicated on the nameplate of the control box corresponds to the local mains voltage before installing the box.
- The electricity load rating marked on the outlet must have enough current capability and correspond to requirements of the power supply.
- Do not cover the control box in any way.
- During operation ensure the controller will be have plenty of ventilation around the unit and that it will not be covered with any fabrics in the area including curtains, tent sides, flags, etc.
- Improper use of this controller can result in risk of electrical shock and/or fire. Turn off the electricity immediately. Do not try to repair the appliance by yourself. Please contact Heat Outdoors or a suitably qualified electrician for maintenance.
- Turn off the electricity before performing any maintenance work.
- Keep young children away from the controller. It is recommended to install the controller out of the reach of children.
- The box should only be installed by a qualified electrician.
- Do not modify the controller by adding other programmers, timers, individual control systems as this may cause the unit to malfunction catch fire if installed incorrectly

## Key Features & Control Details

- Energy saving - provides heat for a pre-determined time period.
- Extends Lamp Life.
- Soft-start /zero-voltage switch-off.
- Low-cost.
- Easy to install.
- Waterproof switch (IP65)
- Timing knob: allows the connected heater to be turn on for a set time between 1-60 minutes.
- LED indicator: flickers on standby.

# Specifications

Specification	LDCB-D02
Voltage (V)	230VAC, 50/60Hz
Power consumption (W)	6000W Max
IP	IP65

## Operation & Installation Instructions

- Remove all packaging material and check the box and the waterproof outlets for signs of damage.
- Pay attention to the mounting position and all mounting material. Use the mounting template diagram (fig 1, page 5) to position the mounting holes.
- Ensure the control box is not installed in an area that could be at risk of being exposed to extreme adverse weather conditions.
- Open the lid of the control box, connect the power cord and the heater power cable to the prompt on the PCB. Consult the wiring diagram (fig 2, page 6).
- Adjust the timer knob inside of the unit when installing for the desired heater operation time. This can be set for between 1-60 minutes periods.
- Return the lid of the box and tighten the screw.
- Unit must be fitted with the glands facing down.

## Cleaning and Maintenance

- This box is manufactured from robust and maintenance-free aluminum with a protective coating. There are no user serviceable parts inside.
- Before cleaning, remove the plug from the power outlet and wait until the box is sufficiently cooled.
- Wipe the box only with clean and lint-free cloth or a soft brush.
- Never use abrasive cleaners, scrubbing brushes and chemical cleaners for cleaning!
- To protect against electrical shock and danger to life, do not immerse the cord, plug, or any part of this box in water or any other liquid.

# Disposal



In accordance with European Directive 2001/96/EG concerning used electrical and electronic appliances (waste electrical and electronic equipment – WEEE), please return any electrical equipment that you will no longer use to the collection points provided for their disposal.

This symbol indicates that the appliance cannot be treated as normal domestic trash, but must be handed to a collection point for recycling electric and electronic appliances.

Information concerning where the equipment can be disposed of can be obtained from your local authority.

# Customer Service

- Repairs must be carried out by authorized specialists, thus ensuring electrical safety.
- Please contact with the service agent or a suitably qualified electrician.
- Improper repairs could lead to danger to the user.

Warranty does not cover damage of failure which results from alteration, accident, misuse, abuse, neglect, commercial use or improper maintenance. In line with our policy of continuous product development we reserve the right to change the product and documentation specifications without notice.

# Product Diagram

Fig 1 - Mounting Template

## Mounting Template

**IMPORTANT!** When wall mounting, the unit must be orientated with the cable glands facing down.

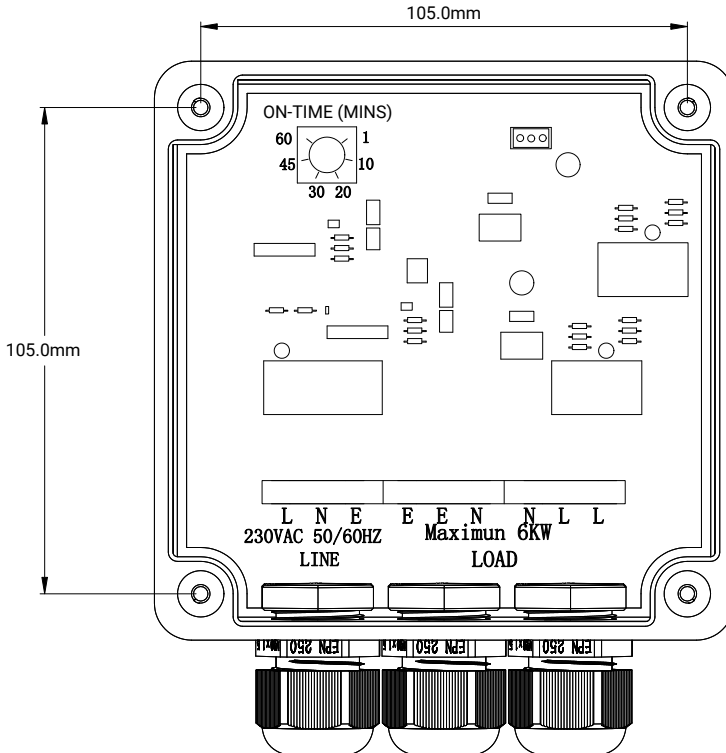

Use this graphic and dimensions to mark four mounting-hole centres prior to drilling

### IMPORTANT!

Drilling of any holes through or impacting the enclosure will immediately invalidate the warranty of the unit.

The unit **MUST** be orientated with the cable glands facing down.

# Product Diagram

Fig 2 - Wiring Diagram

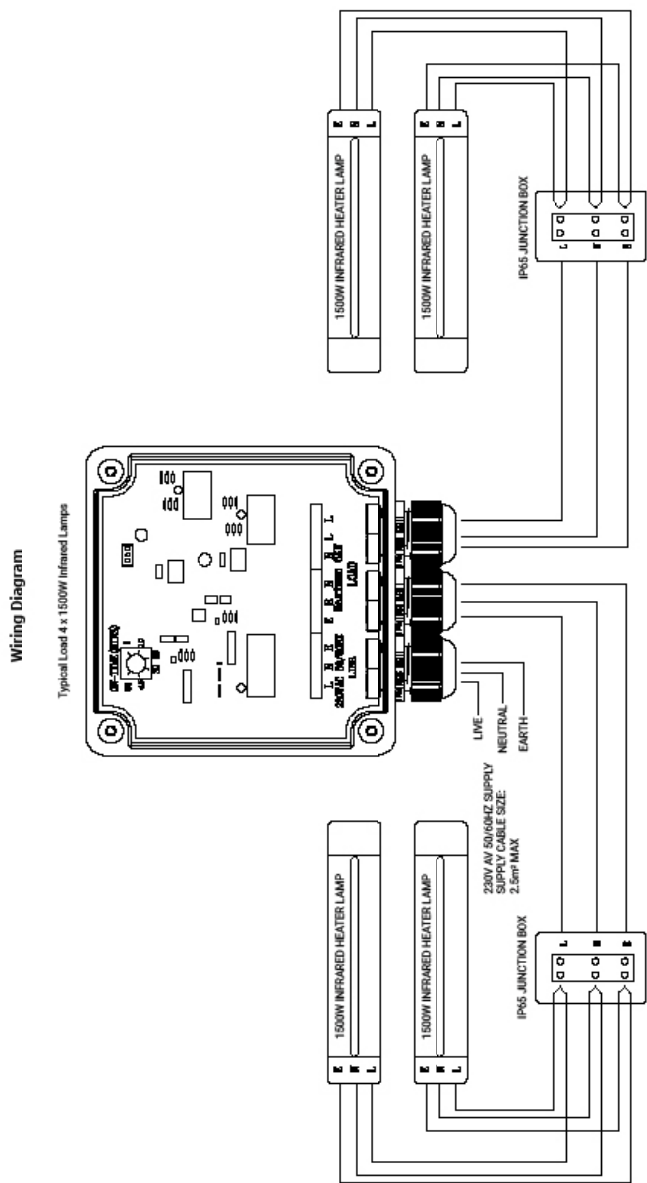





## **Heat Outdoors**

Unit 9, Stort Valley Industrial Estate  
Stansted Road, Bishop's Stortford  
Hertfordshire, United Kingdom  
CM23 2TU

**[www.heat-outdoors.co.uk](http://www.heat-outdoors.co.uk)**  
**01279 466500**  
**[info@heat-outdoors.co.uk](mailto:info@heat-outdoors.co.uk)**